

norstar

.....

**Compact DR5
(with Disconnect
Supervision)
Installer
Guide**

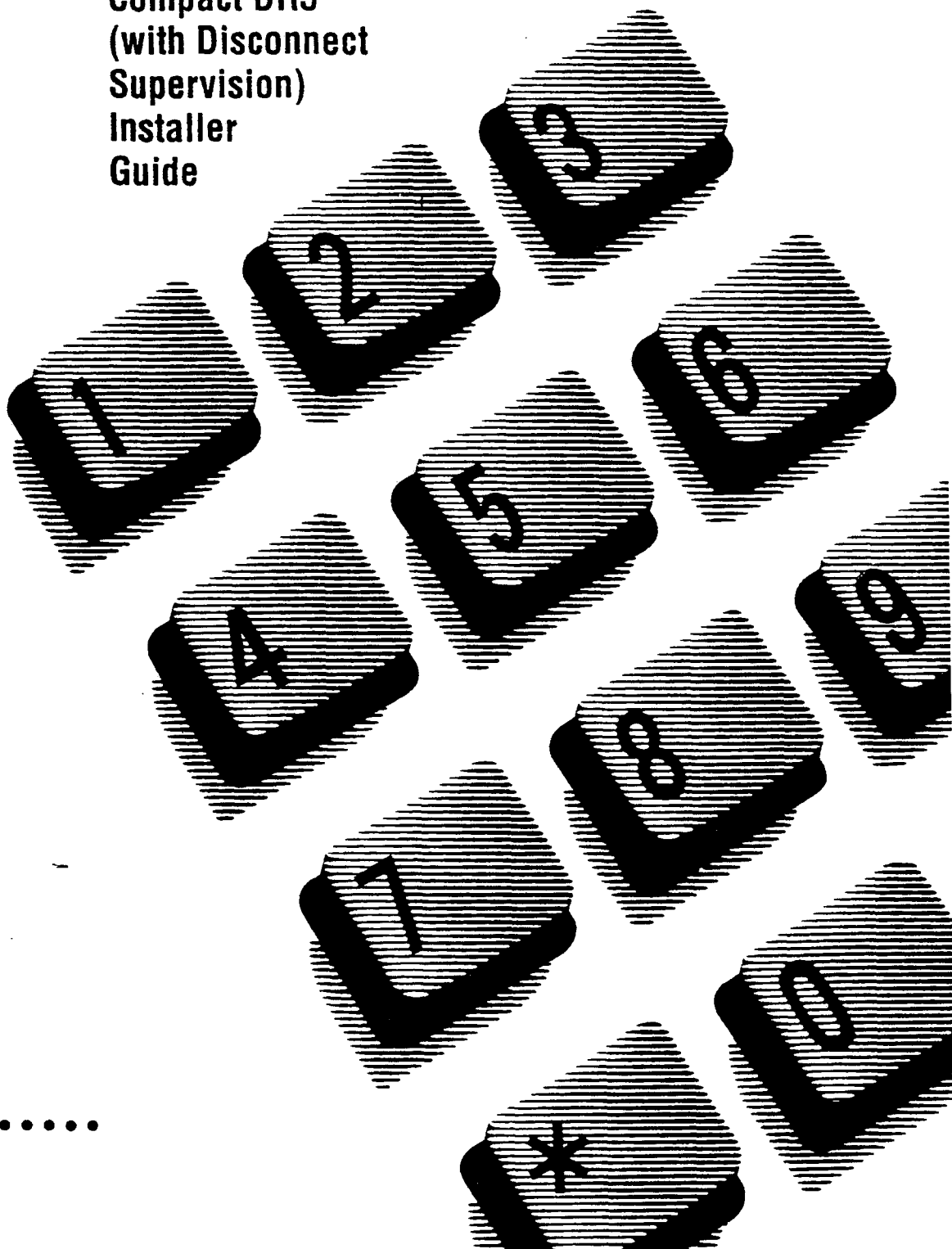

.....

**Compact DR5
(with Disconnect
Supervision)
Installer
Guide**

Norstar and Meridian are trademarks of Northern Telecom
© Copyright Northern Telecom 1995

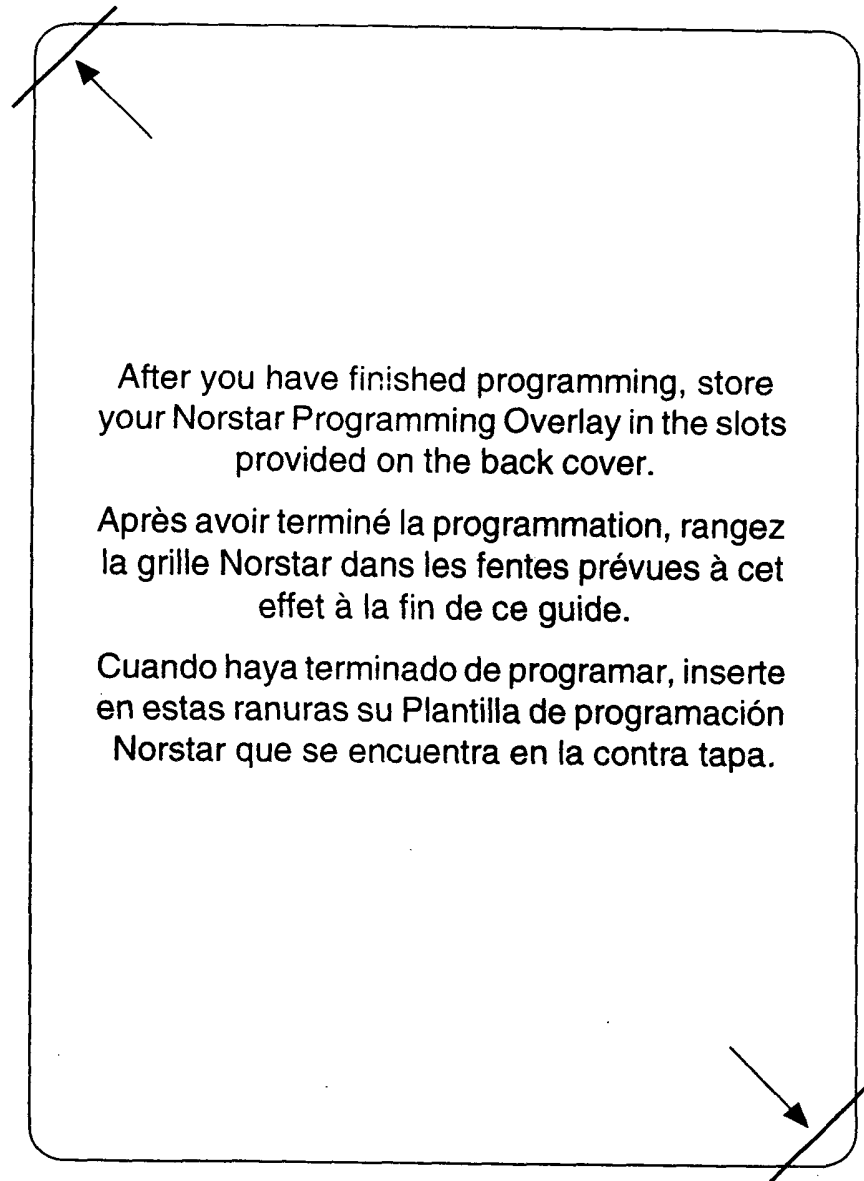
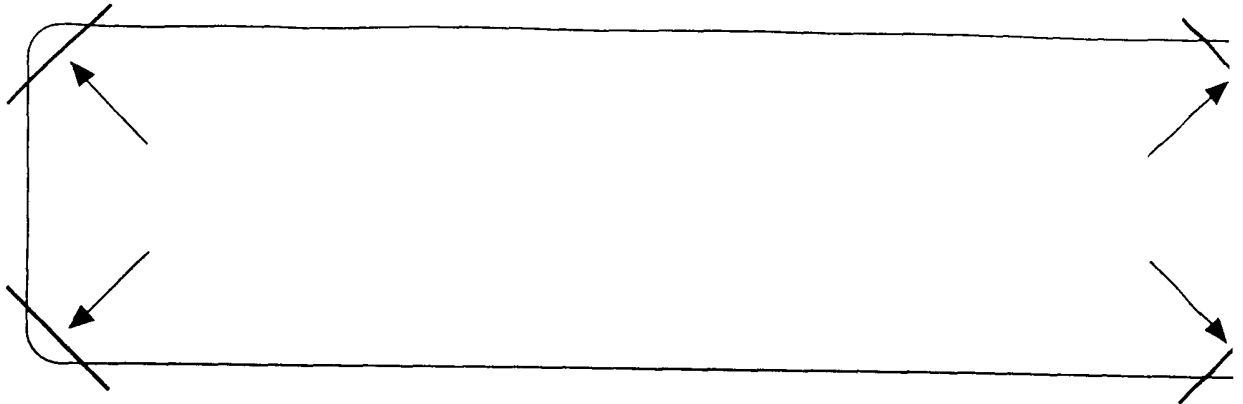

After you have finished programming, store your Norstar Programming Overlay in the slots provided on the back cover.

Après avoir terminé la programmation, rangez la grille Norstar dans les fentes prévues à cet effet à la fin de ce guide.

Cuando haya terminado de programar, inserte en estas ranuras su Plantilla de programación Norstar que se encuentra en la contra tapa.

Regulations

Radio Frequency Interference

WARNING

This equipment generates, uses, and can radiate radio frequency energy. If not installed and used in accordance with the instruction manual, it may cause interference to radio communications. It has been tested and found to comply with the limits for a Class A computing device pursuant to Part 15 of the FCC Rules, which are designed to provide reasonable protection against such interference when operated in a commercial environment. Operation of this equipment in a residential area is likely to cause interference, in which case the user, at his own expense, will be required to take whatever measures may be required to correct the interference. Each Norstar Key Telephone System is assigned an FCC Registration Number and a Ringer Equivalence designation. The number and designation are printed on the Key Service Unit (KSU) label on the front of the unit inside the door.

Registration

The Norstar Key Telephone System is registered with the FCC based upon compliance with Part 68 of its rules. Connection of the Norstar Key Telephone System to the nationwide telecommunications network is made through a standard network interface jack that you can order from your telephone company. Jacks for this type of customer-provided equipment will not be provided on party lines or coin lines.

Interconnect

Norstar Compact equipment meets all applicable requirements of both the Canadian Department of Communications CS-03 and US Federal Commission FCC part 68 and has been registered under files DOC 3322492A and FCC AB67UJ-17156-KF-E (key system) and AB67UJ-17338-MF-E (hybrid system).

Ringer Equivalence Number (REN)

The FCC Registration Label, on the inside of the door on the front of the Key Service Unit (KSU), includes the Ringer Equivalence Number (REN). This number shows the electrical load that your Norstar KSU requires from your telephone line. If the KSU requires more electrical current than your telephone company's central office equipment can provide, your telephones may not ring and you may have difficulty dialing telephone numbers.

Call the telephone company to find out the total REN allowed for your telephone line(s).

Hearing Aid Compatibility

Norstar telephones are Hearing Aid compatible, as defined in Section 68.316 of Part 68 FCC Rules.

Electromagnetic compatibility (EMC)

Radiated emissions

Norstar Compact equipment meets all FCC part 15, class A radiated emissions requirements.

Conducted emissions

Norstar Compact equipment meets all FCC part 15, class A conducted emissions requirements.

Safety

Norstar Compact equipment meets all applicable requirements of both the Canadian Standards Association C22.2 No. 0.7 M1985 and US Underwriter's Laboratory UL-1459, issue 1, and has been registered under files CSA LR58855-12 and UL E115515 88NK16650.

Telephone Company Registration

It is usually not necessary to call the telephone company with information on the equipment before connecting the Norstar Key Telephone System Key Service Unit (KSU) to the telephone network but, if the telephone company requires this information, provide the following:

- Telephone number(s) to which the Key Service Unit (KSU) will be connected
- FCC Registration Number
(on label affixed to KSU, inside the door)
- Ringer Equivalence Number
(on label affixed to KSU, inside the door)
- USOC Jack
RJ-21X
- Service Order Code
(SOC) 9.0 F
- Facility Interface Code
(FIC)02LS2

Use of a Music source

In accordance with U.S. Copyright Law, a license may be required from the American Society of Composers, Authors and Publishers, or similar organization if Radio or TV broadcasts are transmitted through the Music On Hold or Background Music features of this telecommunication system.

Northern Telecom Inc. hereby disclaims any liability arising out of the failure to obtain such a license.

This digital apparatus does not exceed the Class A limits for radio noise emissions from digital apparatus set out in the Radio Interference Regulations of the Canadian Department of Communications.

Rights of the Telephone Company

If the system is determined to be causing harm to the telephone network, the telephone company may discontinue your service temporarily. If possible, the telephone company will notify you in advance. If advance notice is not practical, you will be notified as soon as possible. You will be given the opportunity to correct the situation and you will be informed of your right to file a complaint to the FCC. Your telephone company may make changes in its facilities, equipment, operations or procedures that could affect the proper functioning of your system. If it does this, you will be notified in advance to give you the opportunity to maintain uninterrupted telephone service.

In the event of an equipment malfunction, all repairs will be performed by Northern Telecom Inc. or by one of its authorized dealers.

Address of a repair facility

USA

Northern Telecom Inc.
Product Service Center
640 Massman Drive
Nashville, TN
37210
Attn. RA# _____

Canada

Northern Telecom Canada Ltd.
150 Montreal-Toronto Blvd.
Building C, Doors 33 and 34
Lachine, Quebec
H8S 1B6

Contents

Preparation 1-1

- KSU Location requirements 1-1
 - Mounting requirements 1-1
 - Equipment for mounting the KSU 1-2
 - Internal wiring requirements 1-2
 - Electrical requirements 1-2
 - Norstar as an OPX 1-3
-

Installing the KSU 2-1

- External lines and internal wiring 2-2
 - Internal wiring chart 2-3
 - Installing the Emergency Telephone 2-4
 - Testing the Emergency Telephone 2-4
-

Installing Norstar telephones 3-1

- Installing a wall-mounted telephone 3-2
-

Installing optional equipment 4-1

- Auxiliary Ringer (Customer Supplied) 4-1
 - External Music source (Customer Supplied) 4-1
 - External Paging (Customer Supplied) 4-2
-

Powering up the KSU 5-1

Programming 6-1

- Programming overview 6-1
- System Startup 6-1
- Configuration 6-1
- General Administration 6-1
- Set Copy 6-2
- System Version 6-2
- Programming tools 6-4
- Norstar Telephones 6-4
- Programming Record 6-4
- Programming Overlay 6-4

System Startup	6-6
System Startup access	6-6
Entering System Startup	6-7
Choosing the system template	6-8
Configuration	6-10
Configuration access	6-10
Installer Password	6-10
Trk/Line Data	6-12
Line Access	6-16
Call Handling	6-19
Miscellaneous	6-22
System Data	6-26
Set Copy	6-27
Set Copy Options	6-27
Telephone settings which CANNOT be copied	6-28
Telephone settings which CAN be copied	6-29
Entering Set Copy	6-31
System Version	6-32
Entering System version	6-32

Troubleshooting 7-1

Testing the lines and phones	7-1
Analog Terminal Adapter (ATA) trouble	7-2
Auxiliary Ringer trouble	7-2
Call Identification Interface	7-3
Dial tone absent (on external lines)	7-3
External Paging trouble	7-4
Hung lines at a telephone	7-4
KSU down	7-5
Music on Hold/Background Music trouble	7-5
Telephone dead	7-6

Finishing up 8-1

Applying the button labels	8-1
For the customer	8-1
Personal programming	8-2
Call Display services	8-2

Preparation

Check the location where the Norstar system KSU, the telephones, and auxiliary equipment are to be installed.

KSU Location requirements

- Clean, dry, and well-ventilated
- Temperature: 0°C to 50°C (32°F to 122°F)
- Humidity: 5% to 95%, non-condensing
- Location: at least 4 m (13.1 ft) from equipment such as photocopiers, electrical motors, and other equipment that can produce electromagnetic, radio frequency, and electrostatic interference.

Mounting requirements

If a smooth surface is not available, cut a backboard large enough to accommodate the system KSU and the distribution panel.

Chart 1 — KSU dimensions and required clearances

Dimension	Measurement	
Length	55.6 cm	(21.9 in)
Width	35.6 cm	(14 in)
Height	8.7 cm	(3.4 in)
Weight	5.25 kg	(11.6 lb)
Clearance (front)	1 m	(39.4 in)
Clearance (top)	30 cm	(11.8 in)
Clearance (bottom)	30 cm	(11.8 in)

Equipment for mounting the KSU

- screwdriver, diagonal cutters, pliers, connecting tool, pencil, level (optional)
- three 5mm (#10) wood screws, 38 mm (1½ in) long
- 19 mm (¾ in) thick wooden backboard (if necessary)

Internal wiring requirements

All new or existing wiring must meet the following specifications:

- one twisted pair per telephone
- a dc loop resistance less than 59 Ω
- cable length (0.5 mm or 24 AWG) not to exceed 305 m (1000 ft)
- use of a Norstar Station Auxiliary Power Supply (SAPS) to extend the loop up to 790 m (2600 ft) if the cable is longer than 305 m (1000 ft)
- no bridge taps

Electrical requirements

- Non-switched outlet
- ac outlet located not more than 1.5 m (4.9 ft) from the Key Service Unit (KSU)
- For 120V product: dedicated 110 to 120V ac nominal, 50/60 Hz, 15 A minimum service with third wire ground
- For 220V product: dedicated 220 to 240V ac nominal, 50/60 Hz, 15 A minimum service with third wire ground
- For 48V product: refer to the insert packaged with your 48V KSU for specific installation instructions

WARNING

The ac outlet must be equipped with a third wire ground to avoid electromagnetic interference.

Norstar as an OPX

Norstar can be used as an off-premise extension (OPX) from a PBX. In order to support this application, the OPX lines must be engineered not to exceed 8 dB total loop loss from the serving central office to the demarcation point at the Norstar KSU.

1-4 / Preparation

Installing the KSU

Note: Mount the KSU on a backboard with at least 10 cm (3.9 in) of clearance on its left-hand side, and at least 5 cm (2 in) of clearance on its right-hand side (viewed from the front of the KSU).

1. Unpack the KSU and inspect it for damage.
2. Before installing the KSU, open the KSU door 90°. Applying upward pressure, lift the door from its hinges.
3. **Do not turn the power on to the KSU.**
4. Screw the top mounting screw half-way into the backboard.
5. Hang the KSU vertically on the top mounting screw (Figure 1).
6. Make sure the KSU is level.
7. Install the bottom and right-hand side screws. Tighten all screws.
8. Following the instructions on the label, install the Software Cartridge (Figure 2).

Figure 1 — Mounting the KSU

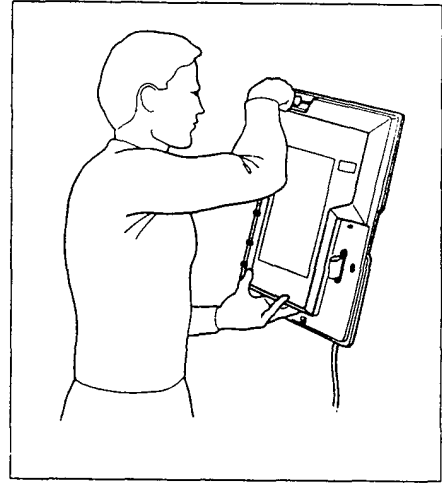
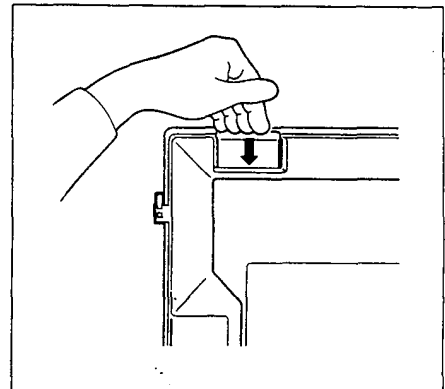

Figure 2 — Inserting the Software Cartridge



CAUTION

Never install or remove the Software Cartridge when the KSU power is on.

External lines and internal wiring

Connecting external lines

1. Cross-connect the external lines from the distribution panel directly to the modular jacks located on the left side of the KSU. Line 01 is connected to the bottom jack. (Each jack is identified with its line number.)
2. Route the line cords on the KSU (Figure 3).

Connecting internal wiring

1. Plug the 25-pair cable into the KSU (Figure 4).
2. Route the cable to the distribution panel.
3. Connect the wires to the appropriate pins on the distribution block. (See Chart 2 — Internal Wiring.)
4. Cross-connect the internal wires to the corresponding pins on the distribution block.
5. Connect the Norstar telephones to your internal wiring loop. A pair of wires is required for each internal telephone. (See Chart 2 — Internal Wiring.)

Figure 3 — Routing the line cords

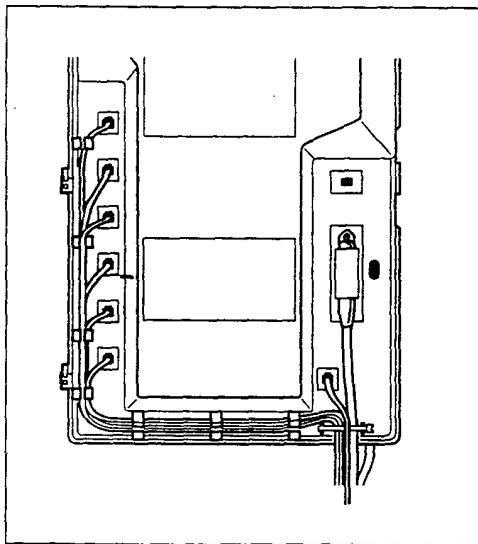
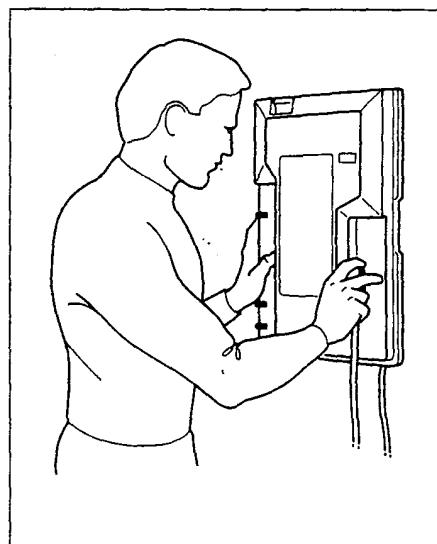

Figure 4 — Plugging in the 25-pair cable



Internal wiring chart

Chart 2 — Internal Wiring

50-Pin Distribution Block				
Pin	Wire Color	Service	Telephone (Defaults)	Port
26 1	White-Blue Blue-White	T R	(21)	1
27 2	White-Orange Orange-White	T R	(22)	2
28 3	White-Green Green-White	T R	(23)	3
29 4	White-Brown Brown-White	T R	(24)	4
30 5	White-Slate Slate-White	T R	(25)	5
31 6	Red-Blue Blue-Red	T R	(26)	6
32 7	Red-Orange Orange-Red	T R	(27)	7
33 8	Red-Green Green-Red	T R	(28)	8
34 9	Red-Brown Brown-Red	T R	(29)	9
35 10	Red-Slate Slate-Red	T R	(30)	10
36 11	Black-Blue Blue-Black	T R	(31)	11
37 12	Black-Orange Orange-Black	T R	(32)	12
38 13	Black-Green Green-Black	T R	(33)	13
39 14	Black-Brown Brown-Black	T R	(34)	14
40 15	Black-Slate Slate-Black	T R	(35)	15
41 16	Yellow-Blue Blue-Yellow	T R	(36)	16
42 17	Yellow-Orange Orange-Yellow	Spare Spare		
43 18	Yellow-Green Green-Yellow	Spare Spare		
44 19	Yellow-Brown Brown-Yellow	Spare Spare		
45 20	Yellow-Slate Slate-Yellow	Spare Spare		
46 21	Violet-Blue Blue-Violet	Spare Spare		
47 22	Violet-Orange Orange-Violet			External Paging (audio signal)
48 23	Violet-Green Green-Violet	N/O Common		External Paging (relay contact)
49 24	Violet-Brown Brown-Violet	N/O Common		Auxiliary Ringer (relay contact)
50 25	Violet-Slate Slate-Violet	Music Ground		External Music (audio signal)

Note: T and R are symbolic representations of the telephone connections and should not be confused with Tip & Ring. Telephone connections are non-polarized.

Installing the Emergency Telephone

An optional Emergency Telephone (ET) automatically connects to Line 01 when the power fails or when power to the KSU is disconnected.

Note: Use only a standard 500/2500 single-line telephone for this purpose.

1. Connect the customer supplied Emergency Telephone to the Emergency Telephone (ET) jack on the lower right hand corner of the KSU panel.
2. Label the telephone: "Emergency Telephone Only. This telephone functions only when ac power to the telephone system is turned off."

Testing the Emergency Telephone

The Emergency Telephone must be tested with the KSU power off.

1. Pick up the Emergency Telephone receiver.
If you hear a dial tone, both the Emergency Telephone and Line 01 are functioning properly.
OR
If you hear no dial tone, check Line 01. Unplug the Emergency Telephone and connect it directly to Line 01 on the distribution block.
2. If you still do not hear a dial tone, check the line connections and operation of the Emergency Telephone.
3. If the previous steps have been verified and there is still no dial tone at the Emergency Telephone, replace the KSU.
4. Repeat the Emergency Telephone test.

Installing Norstar telephones

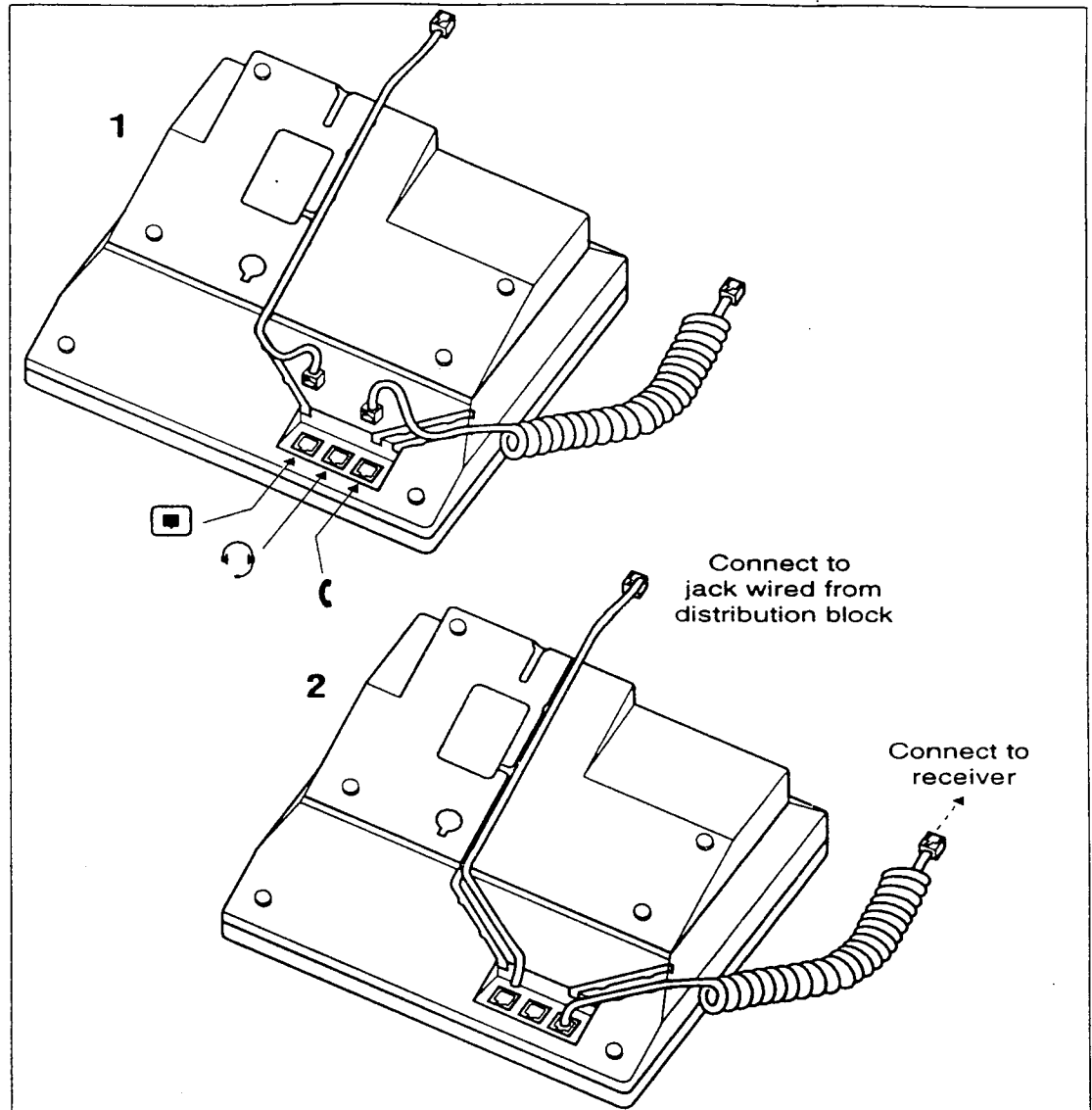

Norstar telephones cannot be used as off-premise extensions (OPX). For OPX applications, use the Norstar Analog Terminal Adapter (ATA) and a single-line telephone. (See the ATA installation card for details.)

Installing a wall-mounted telephone

1. Remove the beveled wall-mounting base from the back of the telephone. Grip the telephone, and with your thumbs, push on the wide edge of the base to pop it out from the telephone.

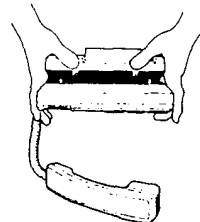

2. Remove the receiver clip from the wall-mounting base. Install the clip in the forward lip of the receiver rest.

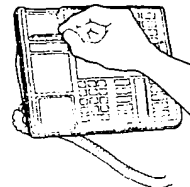

3. Use a screwdriver or similar tool to remove the center knock-out panel in the wall-mounting base.

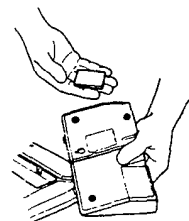

4. Screw the base to the wall (thin end up) so that the wall jack projects through the knock-out.

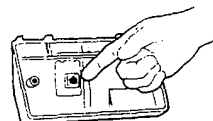

5. Connect one end of the line cord to the telephone line jack (indicated by the symbol below).

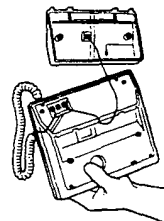

6. Route the line cord through the appropriate cord guide in the bottom of the telephone.

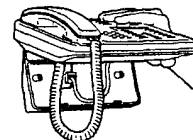

7. Connect the other end of the line cord to the wall jack. Store any spare cord neatly in the base of the telephone and mount the telephone on the base.

WARNING

If the telephone line is supported with auxiliary power, the power source must be a Class 2 power source that is UL and CSA Listed.

Installing optional equipment

Note: Optional equipment must meet with local regulatory approval standards.

Auxiliary Ringer (Customer Supplied)

The Norstar KSU provides a control contact to operate an external ringer. It does not provide ring current or dc voltage. The ringer relay contacts must not draw more than 50 mA from a 30 Vdc source.

1. Follow the manufacturer's installation instructions.
2. Connect the Auxiliary Ringer generator to the 50-pin distribution block as shown in Chart 2 — Internal Wiring.

External Music source (Customer Supplied)

This equipment provides music for the Music on Hold and Background Music features. These features must be enabled through Configuration (see the Programming chapter in this Guide). Refer to the *Compact DR5 System Coordinator Guide* and *Compact DR5 Programming Record* for more information.

The music source can be any approved low-power output device (such as a radio) with a high-impedance earphone jack. The recommended KSU input level is 0.25 Vrms across an input impedance of 3300 Ω .

CAUTION

To avoid damage to audio equipment, ensure that the polarity of the audio input is correct according to the KSU internal wiring chart.

1. Connect the music source and ground to the 50-pin distribution block as shown in Chart 2 — Internal Wiring.
2. Activate the Music on Hold or Background Music feature and adjust the volume at the music source to a comfortable level.

4-2 / Installing optional equipment

Note: Background Music volume for each telephone can also be controlled at the telephone.

External Paging (Customer Supplied)

The paging system uses the speakers on Norstar telephones and can also be used with external loudspeakers provided by the customer. The paging output from the Norstar KSU is 775-mVrms across an input impedance of 600 Ω .

1. Follow the manufacturer's installation instructions.
2. Connect the paging system audio input to the 50-pin distribution block as shown in Chart 2 — Internal Wiring.
3. Connect the paging relay (max. rating: 30 Vdc @ 50 mA) to the 50-pin distribution block as shown in Chart 2 — Internal Wiring.

Note: Norstar external paging does not support talk-back paging equipment unless an external line port is used.

Powering up the KSU

1. Power on the KSU by plugging in the power cord. The red power LED on the KSU should turn on.
2. If the red LED does not turn on, verify that there is power at the ac outlet.
OR
If there is power at the ac outlet, replace the KSU.

Note: Re-install the KSU door once the system is operational.

Programming

Programming a newly installed Norstar system involves the completion of the following programming steps:

- System Startup
- Configuration
- General Administration

Programming overview

System Startup

System Startup is performed only when the system is first installed. System Startup allows you to select one of three programming templates: Square, Hybrid, or PBX. Each template initializes all of the programming data to system wide defaults.

Configuration

Allows programming of basic line and telephone characteristics.

Configuration access code: This code and the Installer password give access to:

- A. Configuration
- B. General admin
- C. Set copy
- D. System Version

General Administration

Allows the customization of the system at installation and on an ongoing basis. (See the *Compact DR5 System Coordinator Guide* for details on Administration programming.)

Administration access code: This code gives access to:

Note: B. General admin is also accessible through the Configuration code. Administration has been given a unique code and optional password so that the System Coordinator can be allowed access to Administration programming, while being denied access to all other programming headings.

Set Copy

This feature is used to copy all of the system programming (Configuration and Administration) from one telephone to another. Personal programming on individual telephones can also be copied, but system-level programming will be copied along with it. Copy appears on the display as C. *Set copy* and is accessible through Configuration programming.

System Version

System Version allows you to note the version numbers of the software in the System Processor (SP) software, residing in the Software Cartridge. System Version appears on the display as D. *System Version* and is accessible through Configuration programming.

Chart 3 — Programming Overview

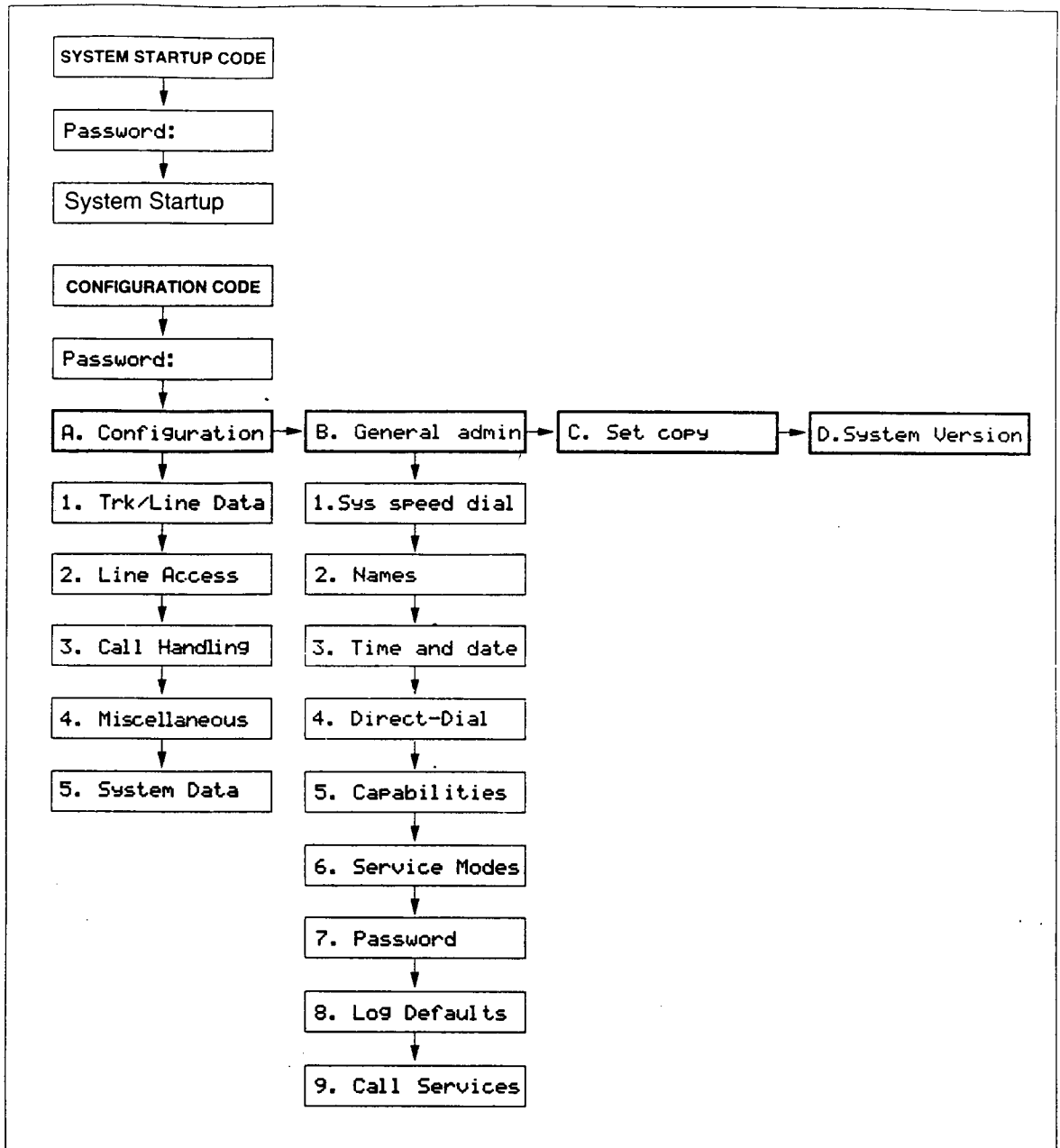

Programming tools

Norstar Telephones

The Norstar M7100, M7208, M7310 and M7324 Telephones can be used with the Compact DR5 system. Programming is done with an M7208, M7310, or M7324 Telephone (Figure 5). The M7100 Telephone cannot be used for programming.

Figure 5 — Norstar Telephones used for programming



Programming Record

The *Compact DR5 Programming Record* may already have been completed before installation. It describes the settings to be programmed into a Norstar system. Also, the *Compact DR5 Programming Record* serves as a record of the settings programmed at initial installation and during subsequent customization of the system.

Default settings: Many of the programming settings are determined during System Startup according to the selected template. Any of these settings may later be changed during programming. In the *Compact DR5 Programming Record*, these default settings are shown in bold characters for the Square template.

Programming Overlay

The Programming Overlay is placed over the buttons of the Norstar telephones, and provides an aid in recognizing the function of the buttons during programming. The Programming Overlay can be found at the end of this Guide.

The Programming Overlay for the M7208 Telephone is placed over all of the eight memory buttons (Figure 6). The Programming Overlay for the M7310 and M7324 Telephones (Figure 6) is placed over the top four memory buttons with indicators.

Figure 6 — Programming Overlay for the M7208 Telephone (top) and for the M7310 and M7324 Telephones (bottom)

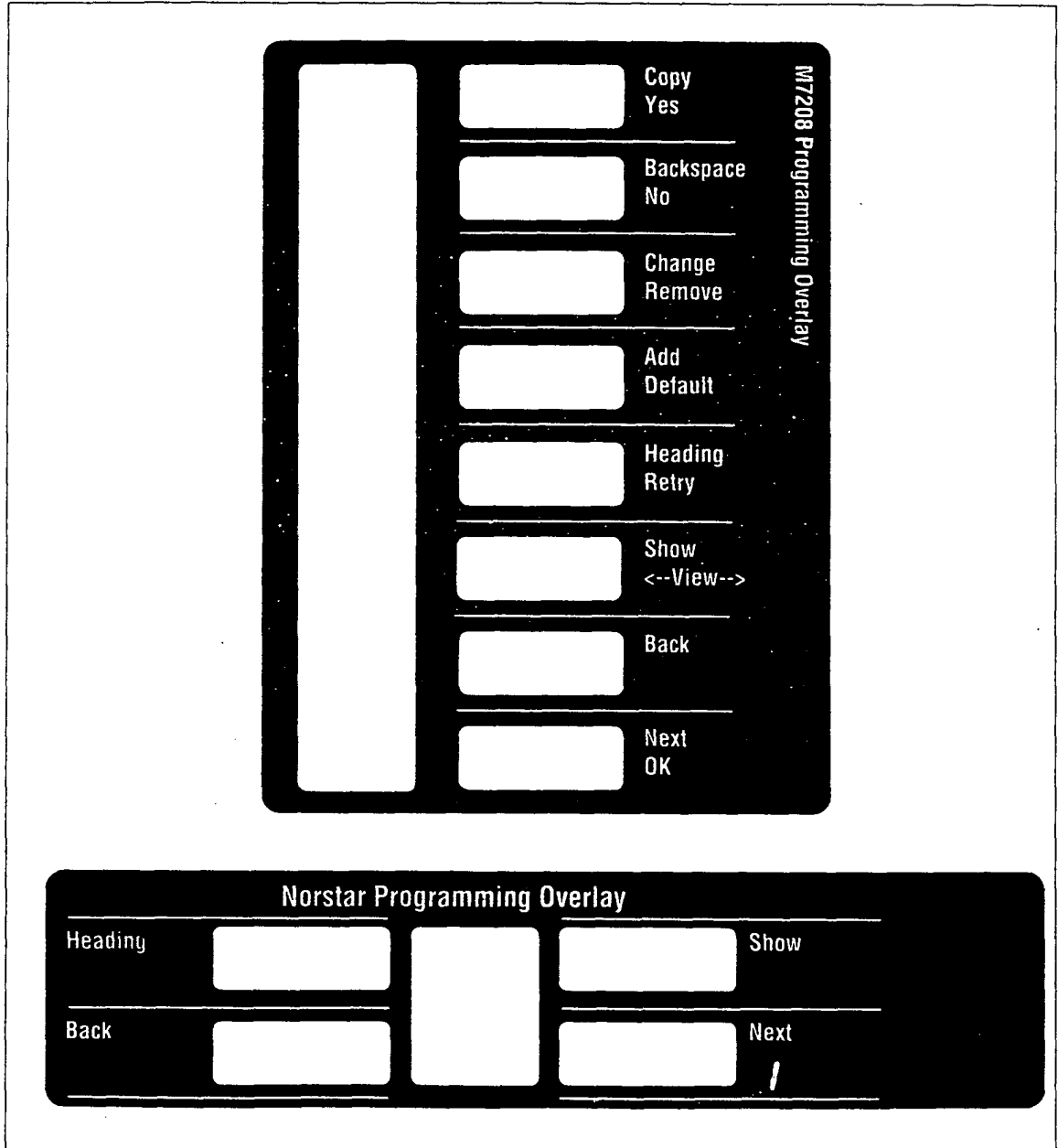

System Startup

Perform System Startup after the system hardware has been installed and powered up.

CAUTION

Startup is to be used for initial installation only, or after a system software upgrade with a new Software Cartridge. Do not use Startup after Norstar is in operation; the procedure erases all system administrative data.

All Configuration and Administration data will be retained for at least three days if the power fails or if the Norstar system is powered off. After three days without power, it may be necessary to perform System Startup again.

Note: Do **not** attempt Directory Number (DN) changes within two minutes of System Startup (using the Change DN's option of 5. *System Data*). Attempting a DN change may disable the ports.

System Startup access

The System Startup code and a password are used only by Installers to access System Startup.

The correct Startup code must be entered no later than 15 minutes after the Norstar system has been powered up. A Startup code entered at any time after the 15 minute interval results in the message *Startup denied*. If this occurs, re-power the system again to prepare for the System Startup process.

Entering System Startup

Note: If at any time you do not wish to continue with entering System Startup, press **RI**.

1. Select a Norstar telephone from which to program. Place the correct Programming Overlay over the buttons of the telephone. A button may be used during programming when its indicator ► turns on.
2. Using the telephone dial pad, enter the System Startup code:

Feature * * 7 8 2 7 8 8 7

Which is the same as:

Feature * * S T A R T U P

3. At the **Password:** prompt, enter the Installer password:
(The Installer password is not shown on the display.)

The default password is 2 6 6 3 4 4 which is the same as C O N F I G. You will have to use the default if this is the first time that Configuration programming has been accessed. If Startup must be performed on an existing system which has already been programmed, the Installer password might have been changed. The change should have been recorded in the *Compact DR5 Programming Record*.

4. If the password is entered correctly, the display shows **Reset memory?** Proceed to change the system template as described in the next procedure.

OR

If the Password has been entered incorrectly, **Password:** remains on the display. Press the **RETRY** display button (or Retry on the M7208 Telephone) and re-enter the correct password.

Note: For the security of system data, do not inform anyone that the Installer password is used for System Startup.

Choosing the system template

System Startup is used during initial installation to choose the appropriate template before starting programming. There are three templates available:

Square: Line 01 and Line 02 are assigned to each telephone.

Hybrid: Each telephone has access to Line Pool A and is assigned Line 01.

PBX: Each telephone has access to Line Pool A, but does not have a line assigned.

1. The display shows `Reset memory?` To continue with System Startup and choose the system template, press YES (or on the M7208 Telephone).

OR

To exit from System Startup, press CANCEL (or on the M7208 Telephone).

2. The display shows `Template: Square`. To accept the Square template, go to step 3.

OR

To select another template, press CHANGE (or on the M7208 Telephone) to select another template.

3. To accept the template shown and exit from System Startup, press . System Startup is complete when the default time and date appear on the telephone display.

Chart 4 — System Startup

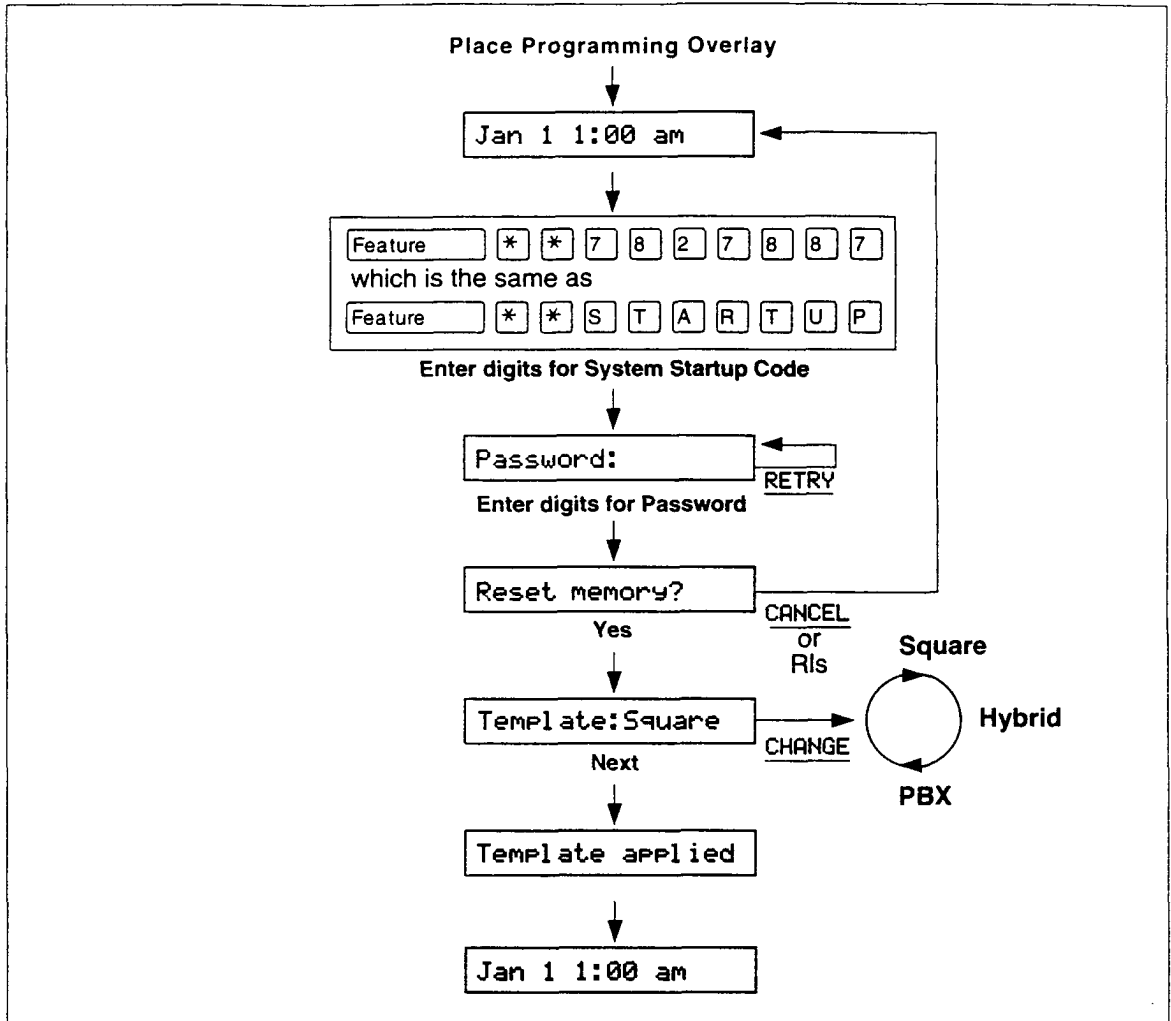

Configuration

A. Configuration programming allows you to specify basic system characteristics for the customer site. Configuration is not accessible to System Coordinators.

Configuration provides access to the following programming sections:

1. Trunk/Line Data
2. Line Access
3. Call Handling
4. Miscellaneous
5. System Data

Configuration access

1. Press * * 2 6 6 3 4 4 which is the same as * * C O N F I G .

Note: For the security of Configuration data, do not give the Configuration code to anyone.

Installer Password

1. At the **Password:** prompt, enter in the existing Installer password. The default password is 2 6 6 3 4 4 which is the same as C O N F I G . You will have to use the default password if this is the first time that Configuration programming has been accessed.
2. If the password is entered correctly, the display shows
A. Configuration.
OR
If the Password has been entered incorrectly, **Password:** remains on the display. Press **RETRY** (or) on the M7208 Telephone) and re-enter the correct password.

Chart 5 — Configuration Overview

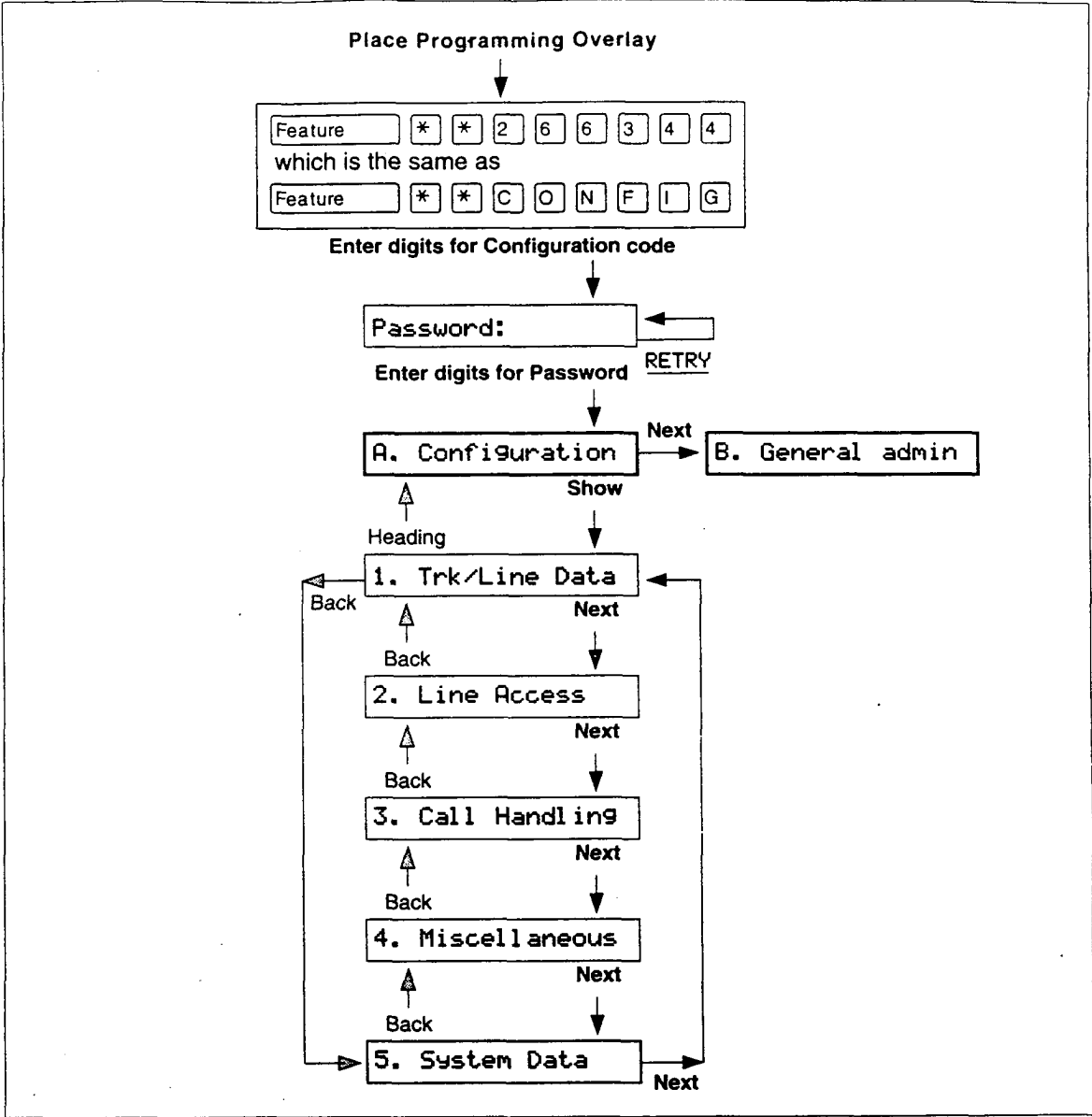

Trk/Line Data

Use 1. Trk/Line Data to program characteristics for each external line.

When you are finished programming the Trk/Line Data settings for a line, you may copy those exact settings to another line by using the COPY display button (or on the M7208 Telephone) at the Show line:_ prompt.

Entering the line to be programmed

Enter any available line number between 01 and 06.

Trunk data

Trunk data settings apply to external lines and include Trunk mode, Dial mode and Full Autohold.

Trunk mode

Trunk mode lets you specify one of two modes of operation for each line: disconnect supervised or unsupervised. The possible settings are Super or Unspr. Super turns disconnect supervision on for the line. Unspr turns disconnect supervision off for the line. The default is Unspr.

Disconnect Supervision, also referred to as loop supervision, releases an external line when an Open Switch Interval (OSI) is detected during a call on that line. This prevents the line from remaining unavailable for other Norstar users.

You should only assign the supervised mode to CO lines that provide an Open Switch Interval (OSI) message. The use of lines that do not have the OSI feature available (or lines set as unsupervised) for incoming calls, results in the inconsistent operation of the Line Redirection feature, the ability to disconnect from a conference that involves two external callers, and the ability to transfer an incoming external call to an external number.

- The duration of an OSI before Norstar disconnects a call is programmed in the Disconnect Supervision delay setting of Miscellaneous programming.

Dial mode

A dial mode can be assigned to each line. The mode defines the signaling that the line will use. The default mode is Pulse. The other possible mode is Tone.

- Lines that use Dual Tone Multi Frequency (DTMF) tones, should be set to Tone.

Full Autohold

If you select an idle line, but do not dial any digits, that line is automatically placed on hold when you select another line. The default setting is No, which means that the external line is not held. The other possible setting is Yes.

Line data

Line data settings apply to external lines and include Line type, Prime telephone, Auxiliary ringer and Auto privacy.

Line type

A type can be assigned to each line. The type defines how the line is to be used in relation to other lines in the system. The default type is Public. Other possible types are Private, Pool A, Pool B and Pool C.

- If you define a line as Public, the line can be accessed by more than one telephone.
 - If you define a line as Private, the line can only be assigned to one telephone and the Prime Telephone for that line.
 - If you assign a line to a Line Pool, that line can be available to any telephone that is assigned access to that Line Pool.
 - If a line is assigned to one of the three Line Pools, but the line is not assigned to any telephone, that line can only be used for making outgoing calls.
-

- If a line is assigned to one of the three Line Pools, you must remember that there are still two more programming settings that must be assigned before a Line Pool can be used:
 - You must assign Line Pool Access to telephones in Line Access.
 - You must assign Line Pool access codes in Miscellaneous programming.

Prime telephone

The Prime telephone provides backup answering for the selected line. The default Prime telephone has the internal number 21. Other possible settings are any allowable internal numbers, or None.

- Each line can only have one Prime telephone.
- Any Prime telephone can be assigned to provide backup answering for more than one external line. All of these lines do not necessarily have to appear on a line button with an indicator; however, monitoring lines is made easier if there is a line button for every external line.

Auxiliary ringer

An auxiliary ringer can be enabled or disabled for calls coming in on the line. The default setting is Yes, which means that the ringer will ring. The other possible setting is No.

Auto privacy

Select Yes (the default) to prevent other users who have access to a line on their telephone from using that line while a call is already in progress on the line. Select No, to allow a user to select a line in use at another telephone, and join an established call.

Chart 6 — Trk/Line Data

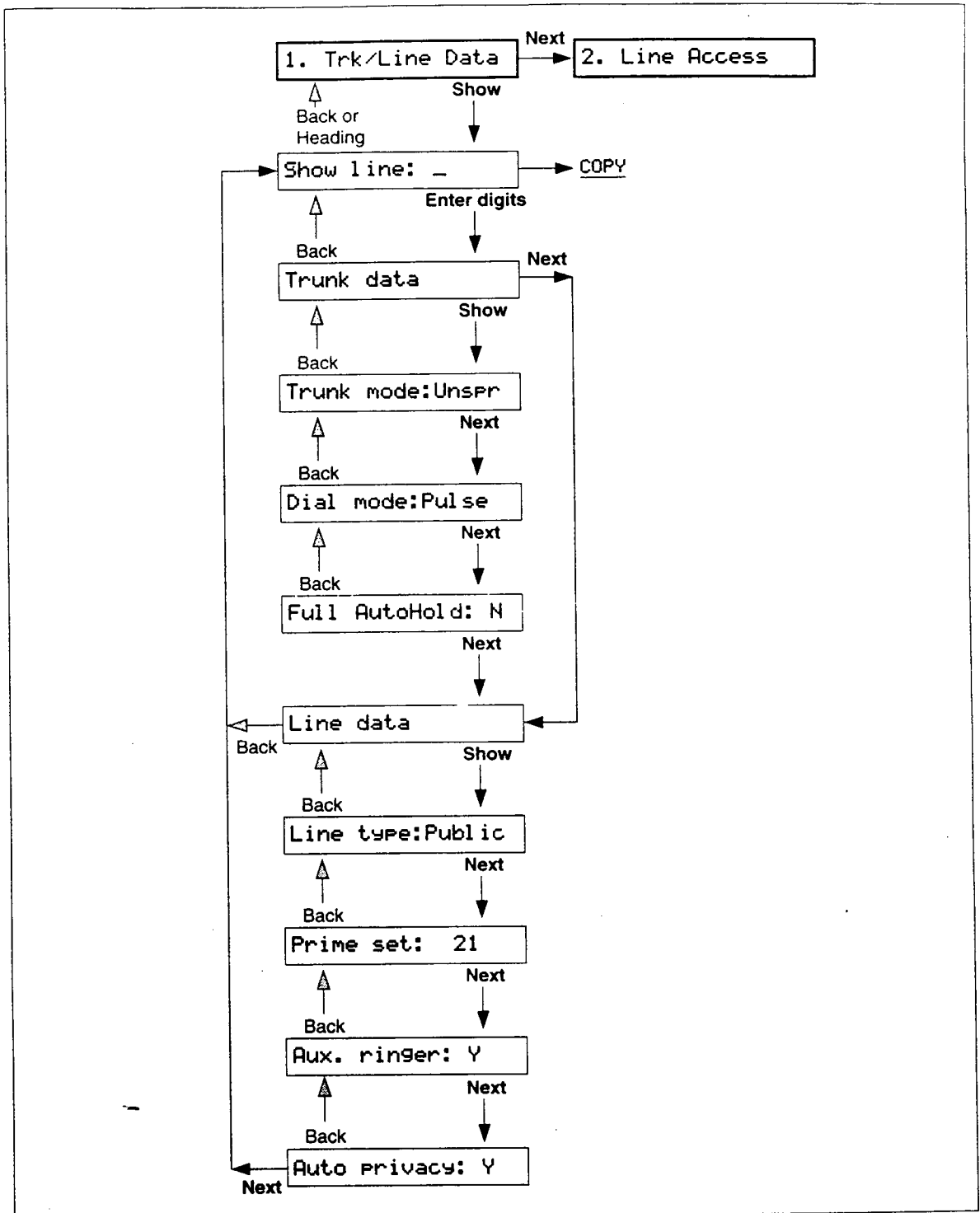

Line Access

Use 2. Line Access to program characteristics for each telephone. These characteristics establish which lines the telephone may use.

When you are finished programming the Line Access settings for a telephone, you may copy those settings to another telephone by using the COPY display button (or on the M7208 Telephone) at the `Show set: _` prompt.

Entering the telephone to be programmed

Enter any available DN. Default DNs range from 21 to 36. DNs can be later changed to a new number in 5. System Data of Configuration programming.

Note: Settings are automatically applied for the Analog Terminal Adapter (ATA) if installed. See the *ATA Installation Guide* for the defaults.

Line assignment

Add or remove lines to assign one or more lines to each telephone. The default line assignments to each telephone are Line 01 and Line 02.

- A Private line can only be assigned to one telephone. (It is also automatically assigned to the Prime Telephone for that line.)
- If you assigned the PBX template in System Startup, a Line Pool is assigned to the telephone instead of external lines. You can add lines if you wish. This would allow the telephone to ring for incoming external calls.
- If a line is assigned to a Line Pool, but is not assigned to any telephone, that line can only be used to make outgoing calls.

Answer DNs

Up to four buttons on a telephone can be programmed for answering calls to the DNs of other telephones. The default is No Answer DNs.

Ringling

For each line and Answer DN assigned to a telephone, you can determine whether incoming calls will ring at the telephone. Possible settings are Ring and No Ring. The default setting is Ring.

Line pool access

You can determine which Line Pool each telephone has access to. Possible settings are Yes and No. The default setting is No for each of the three line pools, which means no telephone has default access to Line pools.

- Assigning a Line Pool to a telephone saves on the number of buttons required for external lines on the telephone.

Intercom buttons

You can determine the number of Intercom buttons on the telephone. Possible settings are 0, 1, or 2. The default setting is 2.

- A minimum of two Intercom buttons are required for conferencing with two other Norstar telephones in the same system.
 - A minimum of one Intercom button is required if internal calls are to be made or received from the telephone or Line Pools are to be accessed from the telephone.
-

Prime line

You can assign the Prime line for each telephone. The Prime line is the first line to be automatically provided at a telephone when you make a call. The appropriate Prime line will depend on the customer's requirements. The default setting is None, which means that no Prime line is assigned to the telephone. Other possible settings are an external line (Line number), Line Pool A, Line Pool B, Line Pool C or intercom (I/C).

- A Prime line is not related to the operation of a Prime telephone.

Chart 7 — Line Access

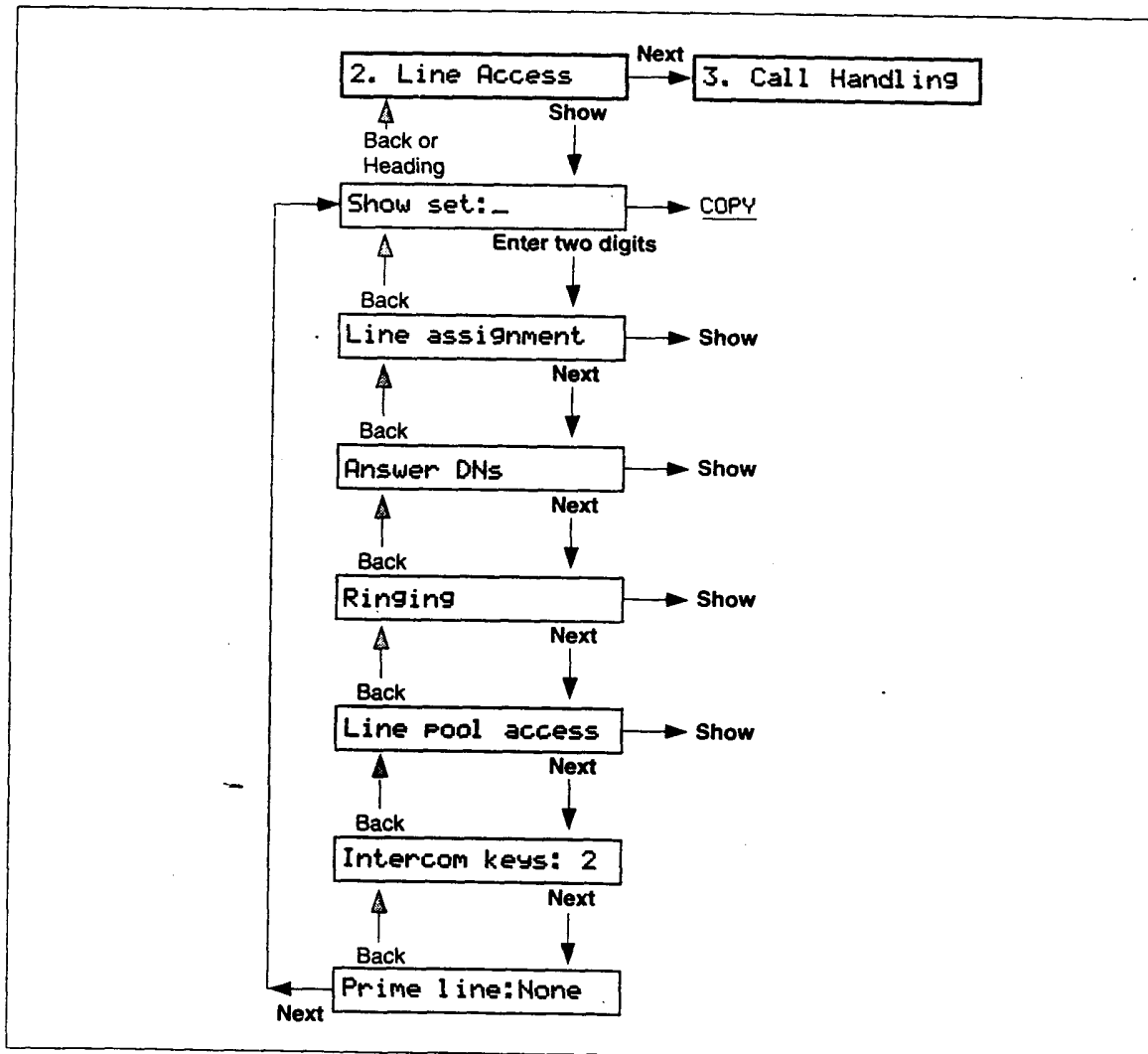

Call Handling

Use 3. Call Handling parameters to program system-wide characteristics for certain call features. These characteristics are not associated in programming with any particular line or telephone.

Held reminder

Choose if the Held Line Reminder feature is to be active for all external lines. Possible settings are Yes and No. The default setting is No. If Yes, the programming menu takes you to the Remind delay setting.

Remind delay

Assign the delay (in seconds) before the Held Line Reminder feature begins at the telephone which has put an external line on hold. Possible delays are 30, 60, 90, 120, 150 and 180 seconds. The default delay is 60 seconds.

- This setting does not appear if Held Line Reminder is not active.

DRT to prime

Choose if the Delayed Ring Transfer to Prime telephone feature is to be active for all external lines associated with the Prime telephone. Possible settings are Yes and No. The default setting is Yes. If Yes, the programming menu takes you to the DRT delay setting.

- Ensure that you have an operational Prime telephone.
- This setting applies only to external lines with an assigned Prime telephone.

DRT delay

Assign the delay (number of rings) before an unanswered external call is redirected to the Prime telephone. Possible delays are 1, 2, 3, 4, 6 or 10 rings. The default delay is 3 rings.

- To estimate the delay time in seconds, multiply the number of rings by six.
- This setting does not appear if DRT to prime is not active.

Transfer callback

Choose the delay (number of rings) before a transferred external call will callback to the originating telephone. The possible delay is 3, 4, 5, 6, or 12 rings. The default delay is 3 rings.

- To estimate the delay time in seconds, multiply the number of rings by six.

Park prefix

Park prefix assigns a one digit code to retrieve a parked call. Any valid digit from 0 to 9, or None, can be assigned. The default Call Park prefix is 1. The Call Park prefix cannot be the same as the first digit of an internal DN, the first digit of a Line Pool access code, the Direct-Dial digit, or the External Line access code.

Park timeout

Assign the number of seconds before a parked external call will callback to the originating telephone. The possible timeout is 30, 45, 60, 90, 120, 150, 180, 300, or 600 seconds. The default timeout is 45 seconds.

Camp timeout

Assign the length of delay before a camped call is returned to the telephone which camped the call. The possible timeout is 30, 45, 60, 90, 120, 150, or 180 seconds. The default timeout is 45 seconds.

Directed pickup

Select Yes (the default) to allow any telephone within the system to answer calls by specifying the ringing telephone's number (unlike Call Pickup Group which only allows pickup of calls within a specified group of telephones). The other possible setting is No.

On hold

Choose what a caller will hear on an external line when the line has been put on hold. Possible settings are Tones, Music, or Silence. The default setting is Tones.

- A customer supplied music source must be connected in

Chart 8 — Call Handling

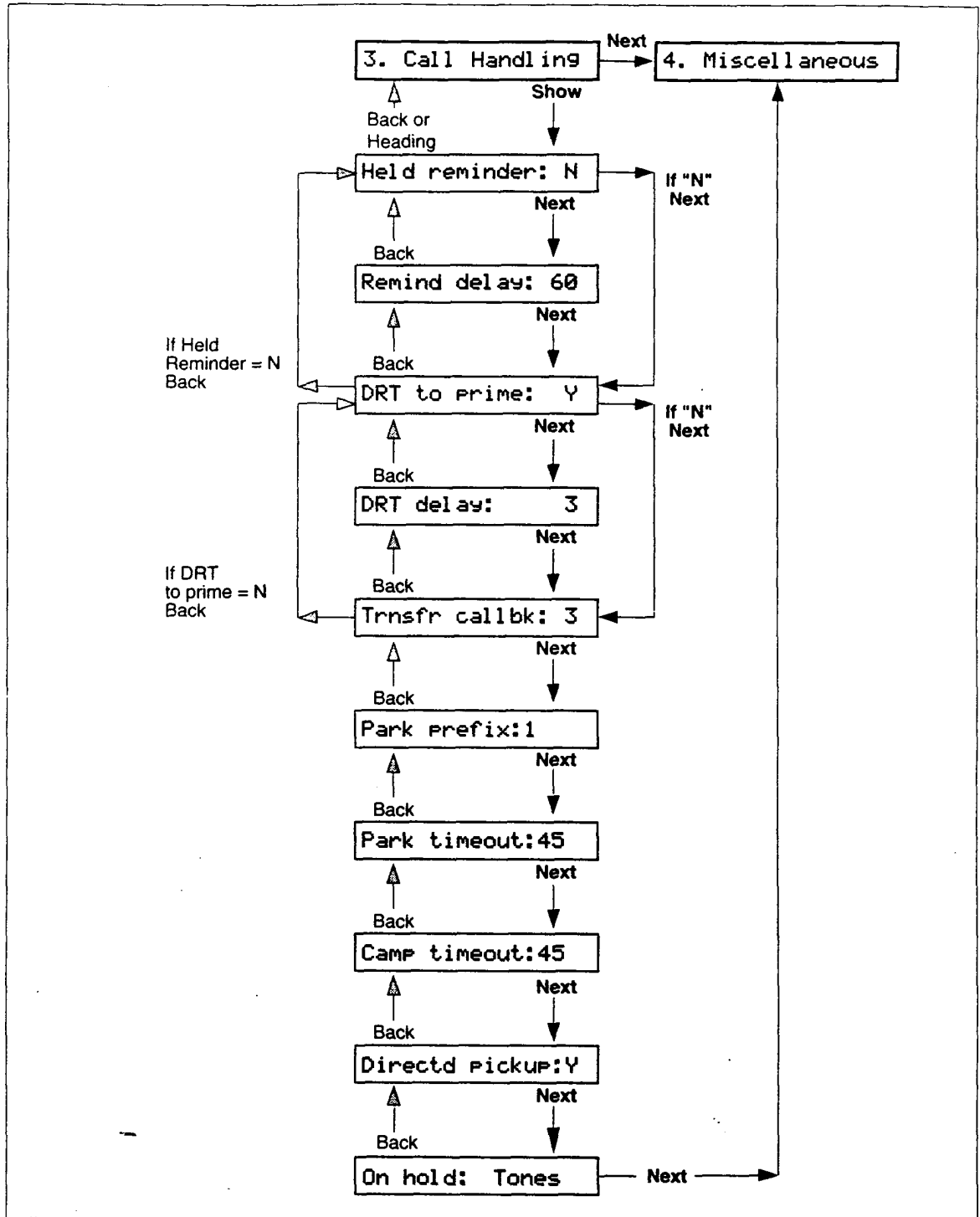

Miscellaneous

Use 4.Miscellaneous settings to program various system-wide characteristics. These characteristics are not associated in programming with any particular line or telephone.

Background Music

Choose if the Background music feature is to be available with the Norstar system. Possible settings are Yes and No. The default setting is No.

- If this feature is enabled, ensure that an external music source has been connected to the KSU. (This music source is also used for the Music on Hold feature.)

Direct-Dial digit

Choose the digit you dial in order to get the Direct-Dial Telephone to ring. The possible settings are any valid digit from 0 to 9, or None. The default setting is the digit zero. The Direct-Dial digit cannot be the same as the first digit of an internal DN, the first digit of a Line Pool access code, the External Line access code, or the Call Park prefix.

Link time

Assign the Link time (in milliseconds). Possible times are 100, 200, 300, 400, 500, 600, 700, 800, 900, 1000 milliseconds. The default Link time is 600 milliseconds.

- The Link time depends on the requirements of the host PBX, Centrex, or other switching system that must be accessed by Norstar.
- Link is another name for Recall or Flash.

Telephone relocation

Choose if the Set Relocation feature is to be active. Possible settings are Yes and No. The default setting is No.

- It is advisable to turn Set Relocation on after the telephone installation and programming has been done. This provides you with more flexibility in testing equipment. If this feature is disabled, and a telephone is moved, that telephone's internal number and Administration data remain with the physical port.

- If new telephones are being installed at the same time that other telephones are being relocated, you should perform the following procedure to ensure that Set Relocation occurs:
 1. Select Yes to turn on Set Relocation.
 2. Unplug the telephone that is to be relocated.
 3. Plug the telephone into its new location.
 4. Plug a new telephone into the old location of the telephone that was moved.

Host delay

Host delay programs the delay in milliseconds between the selection of an outgoing line and the moment that Norstar sends dialed digits or codes on that line. Possible delays are 200, 400, 600, 800, 1000, 1200, 1400, 1600, 1800 or 2000 milliseconds. The default is 1000 milliseconds.

Disconnect Supervision delay

Disconnect Supervision delay allows you to specify the duration of an Open Switch Interval (OSI) before the Disconnect (or loop) Supervision feature disconnects a call on a supervised external line. Possible settings are 60, 100, 260, 460, or 600 milliseconds. The default is 460.

- Disconnect Supervision is assigned to each line with the Trunk mode setting in the Trunk data section of Configuration programming.

External code

The External code allows an M7100 Telephone or an ATA to access external lines. Any valid digit from 0 to 9, or none, can be assigned. The default is 9. The External Line access code cannot be the same as the Call Park prefix, the Direct-Dial digit, the first digit of a Line Pool access code, or the first digit of an internal DN.

Line pool codes

Line Pool access codes are used to specify the line pool you wish to use for making an outgoing external call. Assign Line Pool access codes for each of the three possible Line Pools. The possible settings are a one to four digit number or None. The default setting is none.

- A Line Pool access code cannot start with the first digit of an internal DN, the Direct-Dial digit, or the Call Park prefix.
- A Line Pool access code takes precedence over the External Line access code if there is a conflict.
- Line Pool access codes starting with the same number must be the same length.
- Ensure that the System Coordinator knows the codes.

Installer password

This allows you to change the Installer password for access to Configuration programming. The possible setting is any combination of one to six digits. The default Installer password is

2 6 6 3 4 4 which is the same as C O N F I G .

- The default password is required to first gain access to Configuration programming. However, it is advisable to change that password to a new one.
 - Remember to record the new Installer password in the *Compact DR5 Programming Record*.
 - It is easier to remember the password if the digits spell a word.
-

Chart 9 — Miscellaneous

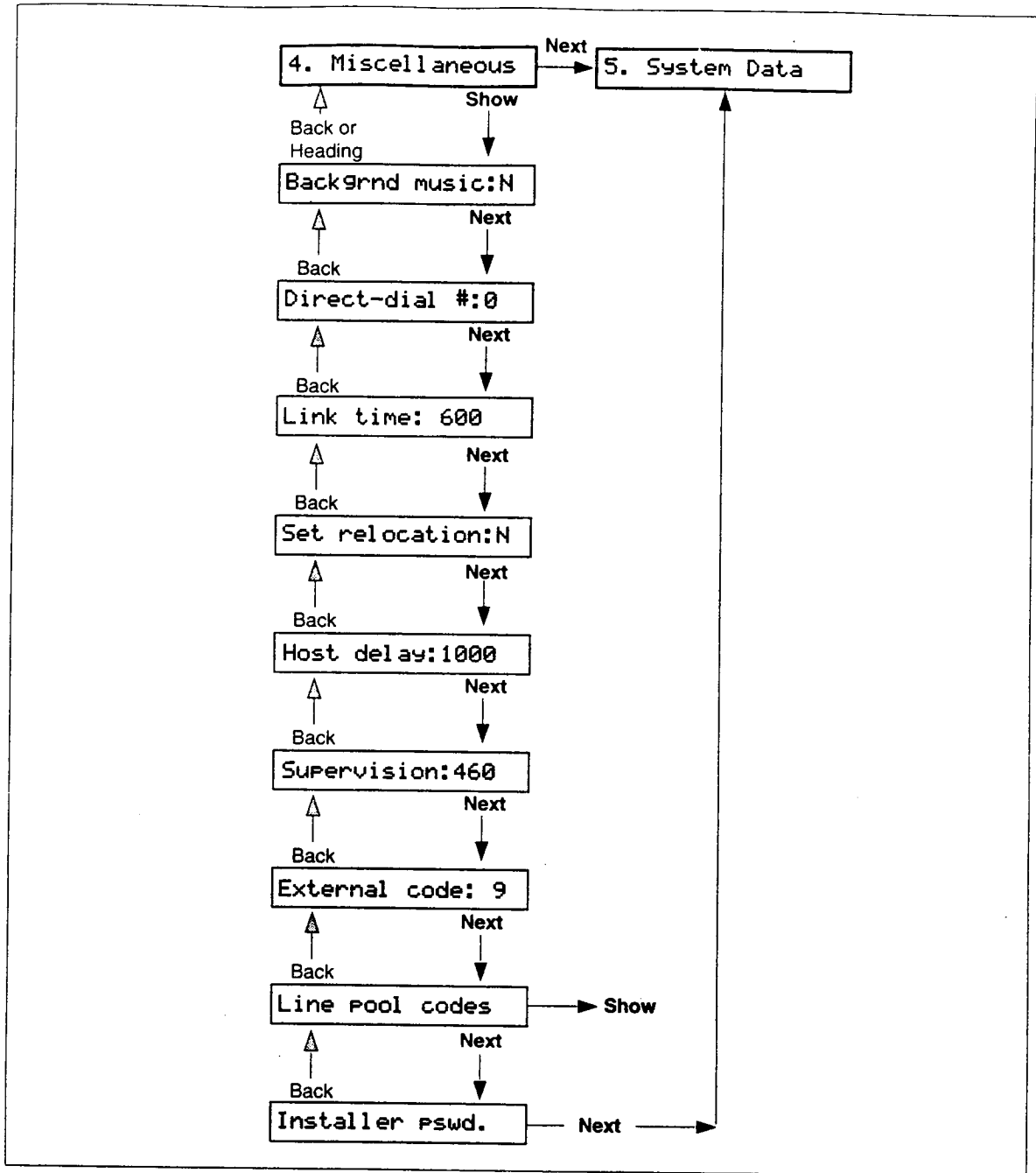

System Data

Use 5. *System Data* to change the internal number or Directory Number (DN) of an individual telephone.

Note: Do not attempt internal number changes within two minutes of System Startup or you may disable the ports.

Individual DNs

Enter the appropriate internal number when you are prompted for the old and the new internal number. A message will appear on the display if either internal number is invalid. The possible settings are any valid internal number between 20 and 99. The default internal numbers for telephones range from 21 to 36.

- No internal number changes occur until the Configuration session ends. (Press the button.)
- There can be only one telephone for each internal number.
- If the "new internal number" already existed for another telephone, that telephone will be given the "old internal number".
- The first digit of an internal number cannot be the same as the External Line access code, the Direct-Dial digit, the Call Park prefix, or the first digit of a Line Pool access code.

Chart 10 — System Data

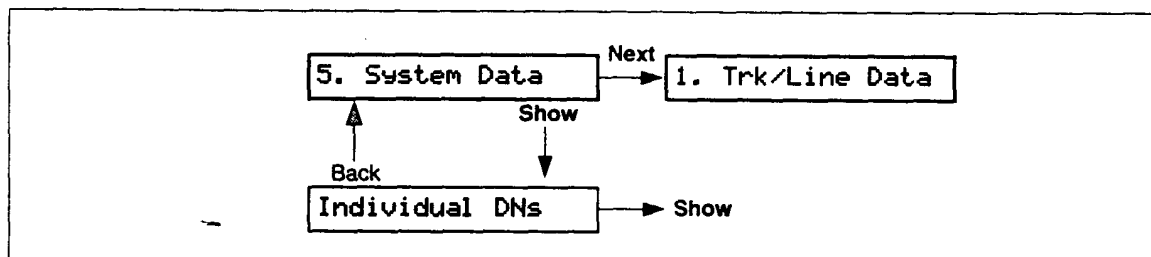

Note: If you change a DN, you cannot continue programming in any of the other sections while in the same Configuration session. Press the button to end the session.

Set Copy

Use **C. Set copy** for copying programmed data from one telephone to another. You can copy System data only or you can copy both System data and Personal programming (User data). System data is programmed in Configuration and Administration. Personal programming is performed by the user at the individual telephone, and allows the telephone to be customized according to the user's requirements.

Set Copy Options

COPY:SYSTEM data

When this message appears on the display, you can choose to copy System data pertaining specifically to telephones.

COPY:SYSTEM+USER

When this message appears on the display, you can choose to copy System data and Personal programming. Both telephones must be the same model and connected to the system before this option can be used.

Note: Do not confuse **C. Set copy** with the **COPY** display button (or **Copy** on the M7208 Telephone), which is for selective copying of specific groups of settings from one telephone or external line to another.

Telephone settings which CANNOT be copied

System settings in Configuration programming

1. Trk/line Data
 - Private line appearances
 - Prime telephone designation for a line
5. System Data
 - Directory Number (DN)

System settings in Administration programming

2. Names
 - Telephone name
4. Direct-Dial
 - Direct-Dial telephone designation
6. Service Modes
 - Extra-Dial telephone designation
 - Control telephone designation for a line
 - Service mode Ringing telephone designation for a line
9. Call Services
 - Auto Call Info telephone designation for a line
 - Log space

Personal programming

- Autobump
 - Autolog options
 - Contrast Adjustment
 - Dialing modes (Automatic Dial, Pre-Dial, Standard Dial)
 - Log password
 - Ring Type
 - Ring Volume
-

Telephone settings which CAN be copied

Listed below are the telephone related settings which can be copied to a destination telephone, overriding any previous programming.

System settings in Configuration programming

2. Line Access

- Line assignment
- Answer DNs
- Ringing line preference
- Line pool access
- Number of Intercom buttons
- Prime line designation

System settings in Administration programming

5. Capabilities

- Set Filter
- Line/set filters
- Set Lock
- Full handsfree
- Auto handsfree
- Handsfree answerback
- Pickup group
- Paging
- Page zone
- Auxiliary ringer
- Direct-Dial
- Forward on busy
- Forward on no answer
- Forward no answer delay

- Allow redirect
- Redirect ring
- Receive tones
- Hotline
- Priority call

9. Call Services

- Logging set designation
- Show external Voice Message
- First display

Personal programming

If desired, the following Personal settings can be copied along with the System data:

- Programmable button assignments (Internal Autodial, External Autodial, and feature access)
- Language choice
- Personal Speed Dial entries

Entering Set Copy

You can only enter Set Copy through Configuration programming with the Installer password.

After A. Configuration appears on the display:

1. Press twice.
The display shows C. Set copy.
2. Press to go to COPY:SYSTEM data.

Chart 11 — Set Copy

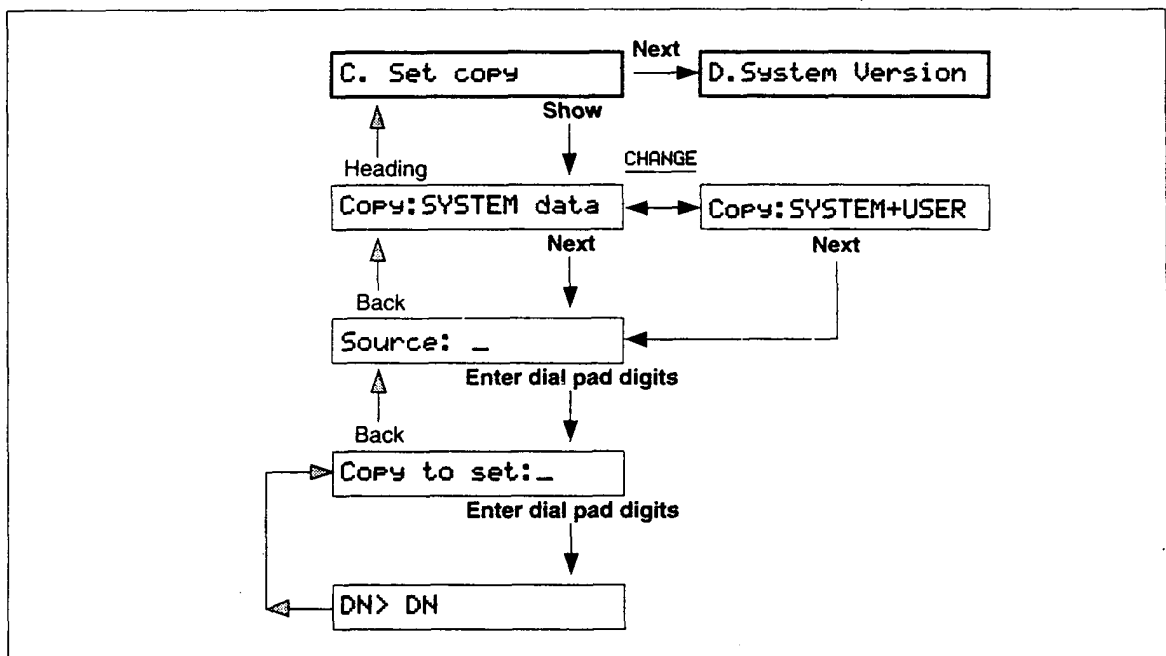

System Version

System Processor (SP) version numbers can be used to determine whether you have the latest software release, and to trace a software fault if one occurs. For instance:

- SP version numbers can indicate a Software Cartridge incompatibility.
- SP and telephone version numbers can indicate a telephone version incompatibility.
- SP and functional terminal version numbers can indicate a functional terminal incompatibility.

Entering System version

You can only enter System Version through Configuration programming with the Installer password.

After **A. Configuration** appears on the display:

1. Press three times.
The display shows **D. System Version**.
 2. Press .
- The display shows the version number of the SP.

Chart 12 — System Version

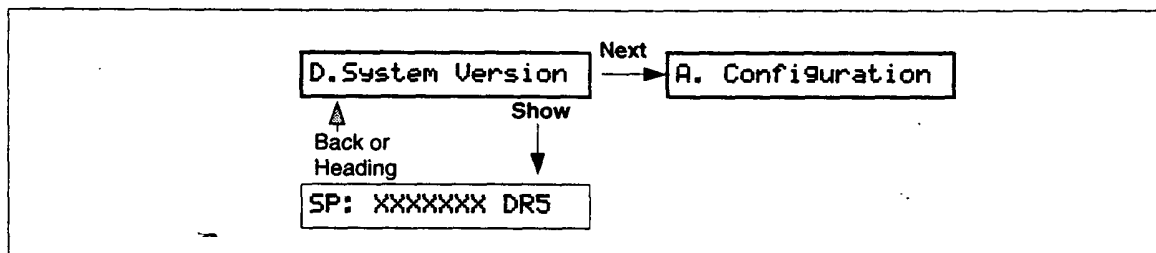

Troubleshooting

Testing the lines and telephones

1. Check all external lines by selecting each line in turn at one of the telephones and verifying the dial tone. If you do not get dial tone, plug a single-line telephone directly into the external line at the distribution panel. If you still do not get dial tone, check all your wiring or contact your telephone company.
2. Check all internal connections by calling each Norstar telephone from another Norstar telephone.
3. Check the quality and clarity of all connections. Check for crackling, static, hums, or any other unusual noise.
4. If there are any problems, refer to other procedures in this chapter.
5. Verify the visual indicators:
 - Select a line or Intercom button. The ► indicator beside that button should appear.
 - Press * .The display should show **Button Inquiry** followed by **Press a button**. Press the button to exit from this feature.

Analog Terminal Adapter (ATA) trouble

1. Check the single-line telephone connection by using an installer's test telephone.
2. Check the connections to the jack.
3. Check the connections to the ATA.
4. Disconnect the ATA and replace it with a working Norstar telephone. If the telephone works properly, this verifies that the KSU is working properly.
5. Verify that programming has been done as described in the *Norstar Analog Terminal Adapter Installation Card*.
6. If the trouble seems to be in the KSU, double check all wiring and programming options. If this does not help, refer to the **KSU down** section of Troubleshooting.

WARNING

This unit must be powered from a Class 2 power source that is UL and CSA listed.

Auxiliary Ringer trouble

1. If the Auxiliary Ringer is used for Service Modes, ensure that Service Modes is activated from the Control Telephone.
2. Check the wiring between the Auxiliary Ringer generator and the ringing device. (See Chart 2 — Internal Wiring.)
3. Check the wiring between the Auxiliary Ringer and the distribution panel.
4. Check the Auxiliary Ringer contact operation with an ohmmeter across the pins.
5. Check that the Auxiliary Ringer is programmed to ring for any of the following programmable settings:

Feature	Programmed in:
Aux. Ringer for a specific line	A. Configuration (1. Trk/Line Data)
Aux. Ringer for a specific telephone	B. General admin (5. Capabilities)
Aux. Ringer for a specific Service Mode	B. General admin (6. Service Modes)

Call Identification Interface

1. Use the Call Information feature on an incoming call to verify the operation of the CII.
2. Check the connections to the CII. Refer to the *CII Installer Card* for installation details.
3. Verify that the programming has been done as described in the *Compact DR5 Programming Record* and the *Compact DR5 System Coordinator Guide*.
4. Verify that you are subscribing to visual call Display services from your local telephone company.
5. Replace the CII.

Dial tone absent (on external lines)

1. Use Button Inquiry (*) to check the programming of a memory button that you think is assigned as an external line.
2. Check for dial tone by using an installer's test telephone at the connections for the external line on the distribution block.
3. Check the connections between the KSU and the distribution block.

External Paging trouble

1. Ensure that you are using the proper feature code (Feature 6 2).
2. Check the wiring between the 50-pin connector and the paging amplifier.
3. Check the wiring between the connections. (See Chart 2 — Internal Wiring.)
4. Check that the paging equipment is operational and that the output from the Norstar KSU is 775 mVrms across 600 Ω .

Hung lines at a telephone

Line indicators that have been solid for a long time are the only visible indication that lines are hung.

A line that has been redirected using Line Redirection may, under some circumstances, remain busy after a call is over. If this happens, the outgoing line for the redirection also remains busy. You can clear this kind of hung line only at the telephone that was used to redirect the line.

1. Select Button Inquiry (Feature * 0) at the telephone that was used to redirect the line.
2. Press the button of the redirected line.
3. Press SHOW or #.
4. Press DROP or *.

Both the redirected line and the outgoing line for the redirection should now be cleared.

KSU down

1. Check that the ac power cord is properly connected.
2. Check that the Software Cartridge is firmly seated in its slot.

CAUTION

Do not install or remove the Software Cartridge when KSU power is on.

3. If ac power is present and the LED indicator on the KSU is off, replace the KSU.

Music on Hold/Background Music trouble

1. Ensure that the volume control (*) is turned up and you are using the Background Music feature code ().
2. Check the applicable Configuration programming settings to ensure that the feature is enabled:

Feature	Programmed in:
Music on Hold	3. Call handling
Background Music	4. Miscellaneous

3. Check the wiring between the music source and the 50-pin connector.
4. Check the polarity of the connections between the music source and the distribution block.
5. Ensure that the music source is turned on, is operational, and has the volume control properly adjusted.

Telephone dead

1. Check for dial tone.
2. Check the receiver cord connection.
3. Check the display. If the display is unreadable, ensure that the display contrast adjustment (*) is appropriate.
4. Check the internal wiring at both the modular jack and the distribution block.
5. Check the internal line.
6. If the problem persists, replace the telephone with a known working Norstar telephone.

Note: An internal line should have between 15 and 20 Vdc across the Tip and Ring when the telephone is disconnected.

Finishing up

If you are required to continue programming, refer to the *Compact DR5 System Coordinator Guide*.

If you are not required to continue programming, give the System Coordinator the *Compact DR5 Programming Record*.

Applying the button labels

If you perform all of the programming for a system, apply the appropriate button labels on the telephones. Before you apply button labels, activate the Button Inquiry feature (*) to avoid activating features as you put the labels onto the buttons.

For the customer

Remember to leave the following items at the installation site:

For the System Coordinator

- *Compact DR5 System Coordinator Guide* (with the Programming Overlays)
- *Compact DR5 Programming Record*
- Optional equipment User Cards (for example, the BLF and ATA)
- Spare button labels and button caps
- Telephone User Cards (for the M7100, M7208, M7310, and M7324 as required)
- *Compact DR5 Telephone Feature cards*
- *Compact DR5 Prime Telephone card*

In the KSU pocket

- *Compact DR5 Installer Guide* (with the Programming Overlays)
- Optional equipment Installation Cards (for example, the BLF and ATA)

Personal programming

Information on telephone feature programming and operation can be found in the *Compact DR5 System Coordinator Guide*.

Call Display services

Your Norstar system can access information contained in Call Display services offered by your public telephone company, and uses that information to provide additional messaging tools to the Norstar user.

Note: You can access Call Display information only if you subscribe to the services, and if you have Call Identification Interface hardware installed. Contact your Customer Service representative for more information.

Call Display information may be shown on your telephone display when a call is alerting, identifying the caller to you. Specific telephones are programmed to receive this information in Administration programming. For more information see the Call Information section in the Programming chapter of the *Compact DR5 System Coordinator Guide*.